



## 一、HD螺旋锥齿换向变速器产品介绍 HD series spiral bevel gear unit

螺旋锥齿换向变速器和换向减速器，其结构特点如下：

- 1、箱体形状为正六面体，能适应不同方位的安装。
- 2、换向器设计使用寿命长，承载能力大，传动平稳，噪音低齿轮线速度可高达40米/秒，传动效率高达94%~98%。
- 3、弧齿圆锥齿轮采用优质低碳合金结构钢，经渗碳淬火热处理，并经研磨跑合，实现精度较高的硬齿面闭式传动。
- 4、HD系列换向器共有七种规格，选型范围大，输出轴形式多样，可满足多种场合的需要。
- 5、可实现减速和增速两种传动方式。

Spiral bevel gear unit,the following is trait:

- 1、the box is hexahedron,which can fit different directin mounting
- 2、long-lift using and big load,sooth transmission,low noise,transmission efficiency can up to 94%~98%
- 3、spiral bevel gears are made of low carbon alloy steel,through quenching and whetting,come to high precision rigidity tooth transmission
- 4、HD series have seven specs,big choosing range,mult-output shaft mode which meet various situation
- 5、enhancing and reducing speed

## 二、型号表示法 Mode designation



HD

### 联接代号及形式

#### Connection symbol and form

HD 输入、输出轴伸式联接 HD coupled of input(output)shaft stretch	HDA 输入轴伸、输出轴装式联接 HDA coupled of input shaft stretch and output shaft mounting
HDF带输入法兰、输出轴伸式联接 HDF coupled of output shaft with input flange	HDAF 带输入法兰、输出轴装式联接 HDAF input flange、coupled of output shaft mounting

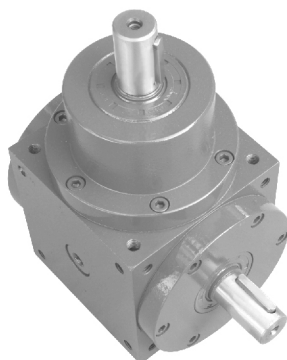

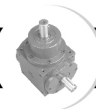

### 三、传动比计算 Ratio account

传动比  $i = \frac{\text{输入转速 } n_1}{\text{输出转速 } n_2}$  当  $i$  大于 1 时为减速,  $i$  小于 1 时为增速

Ratio  $i = \frac{\text{Input speed } n_1}{\text{Output speed } n_2}$  When  $i > 1$  reducing speed,  $i < 1$  adding speed

### 四、型号的选择 Choosing type

1. 选型计算公式: (1)  $P1N = P1Xt$  (每小时起停次数不大于 20 次/小时)
- (2)  $P1N = 1.2XP1Xf$  (每小时起停次数 21~60 次/小时)
- (3)  $P1N \leq PN$

选型功率必须小于或等于许用功率

式中:  $P1N$  为选型功率,  $P1$  为实际需要的功率,  $f$  为使用系数,  $PN$  为许用功率。

Calculation formula: (1)  $P1N = P1Xf$  (not higher than 20/hour)

(2)  $P1N = 1.2XP1Xf$  (start 21-60/hour)

(3)  $P1N \leq PN$

Select power must be lower or equal to fixed power

Note:  $P1N$  is select power  $P1$  is demand power,  $f$  is service factor,  $PN$  is fixed power.

#### 2. 使用系数 $f$ Using quotiety $f$

原动机 Driving machine	每天工作时间 (小时) Working hours/day (hour)	承载类型 Load type		
		均匀负载 Uniform load	中等冲击负载 Medium load	重冲击负载 Heavy load
电动机 汽轮机 液压马达 Motor turbine hydraulic motor	3	0.8	1	1.5
	3~10	1	1.25	1.25
	10~24	1.25	1.5	2
内燃机 Gas engine	3	1.25	1.5	2
	3~10	1.5	1.75	2.25
	10~24	1.25	2	2.5

HD

### 五、热功率校核 Thermal power

1. 热功率计算:  $PGN = PGXf_1 \times f_2$

$PGN > P1$  (自然冷却)

$PGN < P1$  (风扇或油冷却)

式中:  $F1$  为环境温度系数,  $f_2$  为连续工作系数,  $PG$  为换向器热容量,  $P1$  为工作实际需要功率,  $PGN$  为换向器计算热容量。

Thermal power account:  $PGN = PGXf_1 \times f_2$

$PGN > P1$  (nature cooling)

$PGN < P1$  (fan and oil cooling)

Note: surrounding temperature coefficient  $F1$ , continuous work coefficient  $f_2$ , commutator thermal capacity  $PG$ ,  $P1$  actual need power,  $PGN$  account thermal capacity of commutator.



2.环境温度系数f1 surrounding temperature coefficient f1

环境温度℃ Temperature℃	10	20	30	40	50
系数f1 Coefficient f1	1.2	1	0.87	0.75	0.64

3.连续工作系数f2 continuous coefficient f2

每小时工作率% Working efficiency/hour%	100	80	40	40	20
f2	1	1.2	1.4	1.6	1.8

六、热容量PG(自然冷却) thermal capacity PG(nature cooling)

传动比i ratio i	箱体型号 Box type						
	09	11	14	17	21	24	28
1~5	4.5	6.5	11	15.5	24	31	44

七、通用技术规范

universal technology norm

1.键和键槽尺寸符合GB1095-79、GB1096-79的规定，键槽宽度公差：轴N9，轮毂JS9。

2.输出输入轴中心孔均带螺孔，规格如下：

D=11~13mm	螺孔M3	D > 24~30mm	螺孔M10
> 13~16mm	螺孔M5	> 30~38mm	螺孔M12
> 16~21mm	螺孔M6	> 38~50mm	螺孔M16
> 21~24mm	螺孔M8	> 50~85mm	螺孔M20

3.在外形安装尺寸图中，输入轴、输出轴，在转速和扭矩允许的情况下，可将输出轴作为输入轴实行增速传动。

1.The size of the key and keyway must be accord with GB1095-79、GB1096-79,the tolerance of the keyway width:shaft N9,wheelJS9.

2.The center of the output and input shaft has serew the standard as follow:

D=11~13mm	screwM3	D > 24~30mm	screwM10
> 13~16mm	screwM5	> 30~38mm	screwM12
> 16~21mm	screwM6	> 38~50mm	screwM16
> 21~24mm	screwM8	> 50~85mm	screwM20

3.li the diagram of the mouting diemessions,the output shaft can be considered as input shaft if the speed and torque allowed.

八、选型举例

Choosing example

例：搅拌器驱动用螺旋锥齿轮换向器

搅拌器实际需要功率P1=28kw；电机功率P2=30kw，电机转速n1=2000r/min

传动比i=2，换向器装配形式为D，每天工作8小时，每小时连续工作时间为

60% 每小时起停6次，环境温度为30℃。

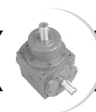

选型：搅拌机原动机为电动机，中等冲击负载，每天工作8小时，按使用系  
f=1.25

选型功率：PIN=P1Xf=28x1.25=35kw(每小时起停6次)

按许用功率：选箱体型号为21，PN=52.4KW >35kw

热功率校核：箱体21，按热容量表PG=24kw

按环境温度系数表：f1=0.87

按连续工作系数表：f2=1.4

PGN=24X0.87X1.4=29.2KW >28KW

自然冷却即可

选的型号为：HD21-2D

Example: beater is driven by spiral bevel gear unit

beater actual need power p1=28kw; motor power p2=30kw, motor speed n1=2000r/min

ratio i=2, mounting type of commutator D, work 8 hours one day, continuous work

hours of every hour: 60%, start stop 6 times/hour, surrounding temperature: 30°C.

Choosing type: driving machine of beater is motor, medium load, work 8 hours/day, according to using coefficient table:

f=1.25

choosing type power: PIN=P1Xf=28x1.25=35kw(start stop 6 times/hour)

according to allowable: choosing box type 21, PN=52.4KW >35kw

thermal power: box 21, according to thermal capacity form PG=24KW

according to surrounding temperature form: f1=0.87

according to continuous work coefficient form: f2=1.4

PGN=24X0.87X1.4=29.2KW >28KW

nature cooling is ok choosing type: HD21-2D

## 九、传动比、输入输出转速及许用输入功率 ratio、input(output) speed and allowable input power

传动比 i	输入转速 n1 r/min	输出转速 n2 r/min	箱体型号 Box type						
			09	11	14	17	21	24	28
			许用输入功率 PN(KW)			Allowable input power PN(KW)			
1	2000	2000	7.55	13.8	29.9	49.2	84	111	188
	1500	1500	6	11	23.9	39.3	67.5	90.5	156
	1000	1000	4.3	7.85	17.2	28.8	50.5	68	115
	750	750	3.4	6.15	13.4	22.8	40.8	54.5	94.2
1.5	2000	1333	5.45	9.7	16.8	33.9	70	92.5	124
	1500	1000	4.3	7.75	13.5	27.2	56.5	75.5	103
	1000	667	3.05	5.45	9.7	19.6	41.2	55.5	75.5
	750	500	2.3	4.25	7.6	15.5	33	44.5	60.5
2	2000	1000	4.2	7.95	14.1	26.2	52.4	71.5	107
	1500	750	3.35	6.3	11.1	20.8	43.2	58.5	88
	1000	500	2.35	4.45	7.85	14.9	31.4	41.9	64.5
	750	375	1.8	3.45	6.2	11.6	25.2	33.6	51
3	2000	667	2.85	5.6	10.1	18.2	34.9	52.4	73
	1500	500	2.2	4.45	7.95	14.4	27.7	41.9	58.5
	1000	333	1.5	3.1	5.6	10.1	20	30.2	42.4
	750	250	1.2	2.4	4.4	7.8	15.7	23.6	33.5
4	2000	500	2.15	3.75	6.8	10.5	23.3	37.7	47.6
	1500	375	1.65	2.9	5.3	8.4	18.5	30.2	38.5
	1000	250	1.15	2	3.75	5.9	13.4	21.7	27.5
	750	188	0.87	1.55	2.95	4.55	10.4	17.1	21.7
5	2000	400	1.4	2.95	5.05	8.05	15.9	28.9	39.4
	1500	300	1.1	2.35	3.95	6.45	12.7	23.4	31.4
	1000	200	0.75	1.6	2.75	4.5	9	16.4	22.4
	750	150	0.58	1.25	2.1	3.45	6.95	13	17.7

注：1.本表的许用功率值为减速是适用，当要求增速时，许用功率数值应乘传动比。

2.输入输出轴超出表中范围时，请与我们联系。



HD09-HD28(i=1~5)输入输出轴伸式联接

HD09-HD28(i=1~5)coupled of input(output)shaft stretch

H D 外形 安装 尺寸

HD outline and mounting dimension

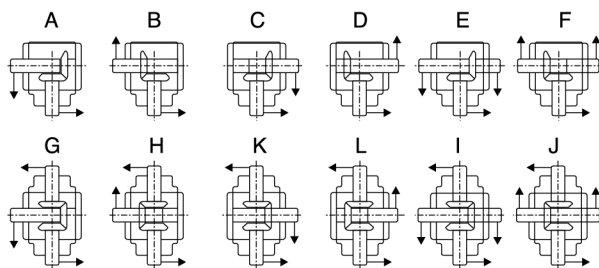
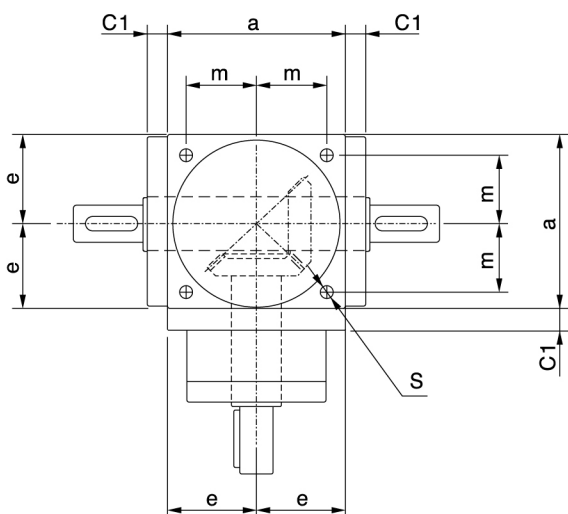
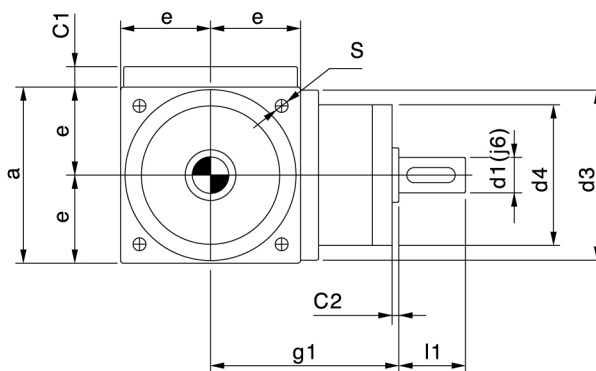
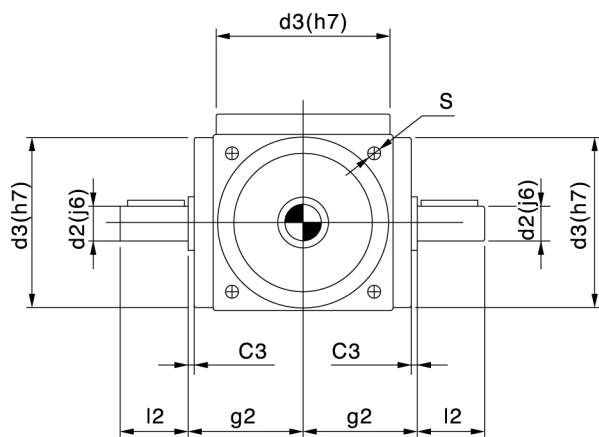

装配形式及旋转方向  
Mounting form and rotation direction

HD

型号 TYPE	a	c1	c2	c3	d2	l2	d3	e	g1	g2	m	s	i=1~2		i=3		i=4		i=5		i=1~3	i=4~5	重量 Weight	加油 oil
													d1	l1	d1	l1	d1	l1	d1	l1				
09	90	12	2	2	18	35	88	45	97	59	36	M6	18	35	16	30	11	23	11	23	72	62	6	0.2
11	110	12	2	2	22	40	108	55	116	69	44	M8	22	40	20	35	16	30	14	25	81	72	10	0.3
14	140	12	2	2	32	50	135	70	157	84	55	M10	32	50	26	45	20	35	16	30	98	81	20	0.4
17	170	15	2	2	40	60	165	85	181	103	67	M12	40	60	32	50	26	45	22	40	118	98	32	1
21	210	18	2	2	45	70	205	105	215	125	85	M16	45	70	38	55	32	50	30	50	128	110	60	2
24	240	18	2	2	55	85	235	120	225	140	95	M16	55	85	45	70	38	55	35	55	138	120	75	2.5
28	280	18	2	2	60	110	275	140	255	160	110	M16	60	110	50	80	45	70	42	70	150	135	115	3



HD09-HD28(i=1:1.5,i=1:2)输入输出轴伸式联接 HD09-HD28(i=1:1.5,i=1:2)coupled of input(output)shaft stretch  
H D 外形 安装尺寸 HD outline and mounting dimension

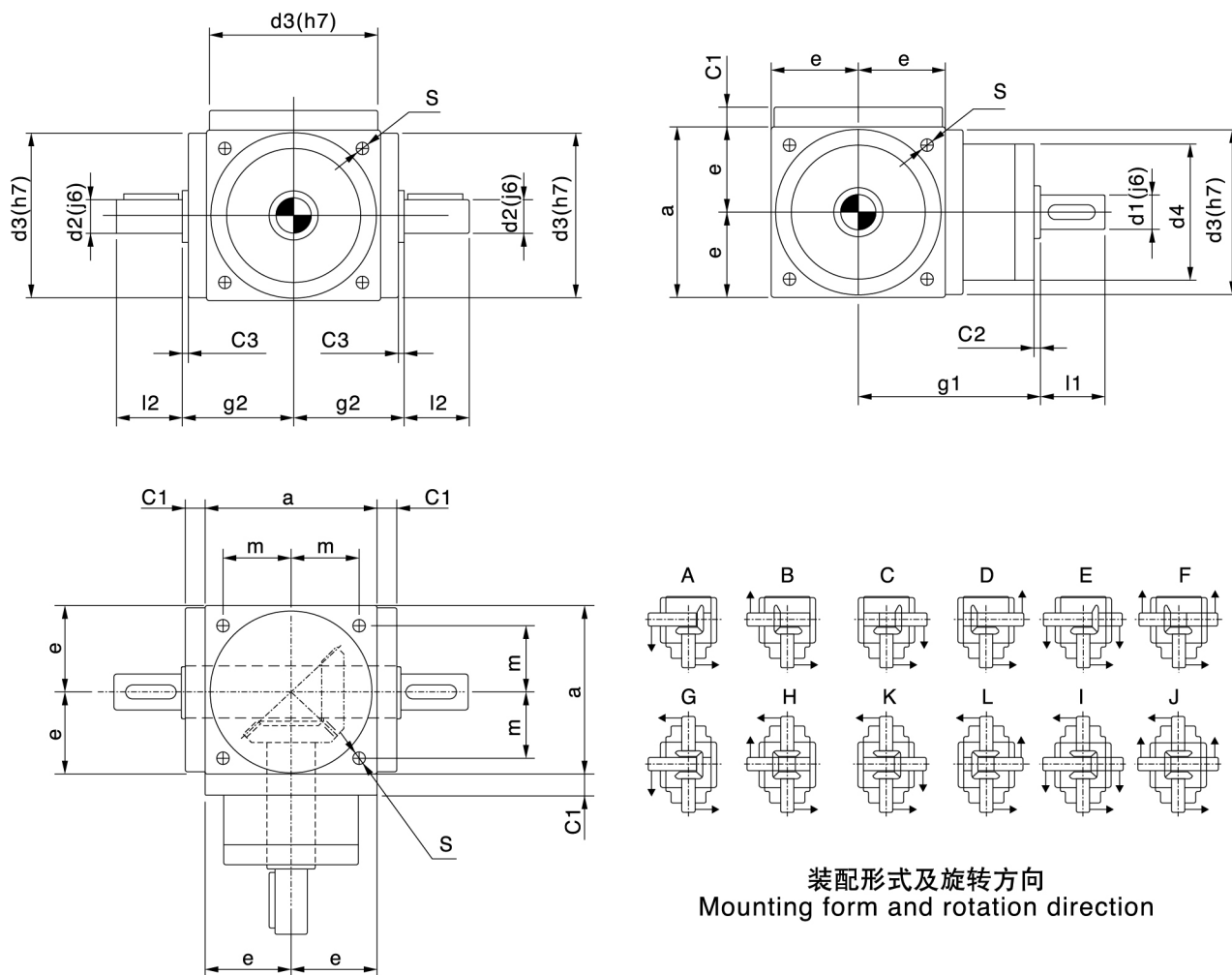

装配形式及旋转方向  
Mounting form and rotation direction

HD

型号 TYPE	a	c1	c2	c3	d1	L1	d3	e	g1	g2	m	s	d4	i=1~1.5		i=1:2		重量 Weight Kg	加油 oil L
														d1	l2	D2	l1		
09	90	12	2	2	18	35	88	45	97	59	36	M6	72	11	23	18	35	6	0.2
11	110	12	2	2	22	40	108	55	116	69	44	M8	81	14	25	22	40	10	0.3
14	140	12	2	2	32	50	135	70	157	84	55	M10	98	16	30	32	50	20	0.4
17	170	15	2	3	40	60	165	85	181	103	67	M12	118	22	40	40	60	32	1
21	210	18	2	2	45	70	205	105	215	125	85	M16	128	30	50	45	70	60	2
24	240	18	2	2	55	85	235	120	225	140	95	M16	138	35	55	55	85	75	2.5
28	280	18	2	2	60	110	275	140	255	160	110	M16	150	42	70	60	110	115	3



HDA09-HDA28(i=1~5)输入轴伸, 输出轴装式联接 HDA09-HDA28(i=1~5)coupled of input shaft stretch and output shaft mounting

HD 外形安装尺寸

HD outline and mounting dimension

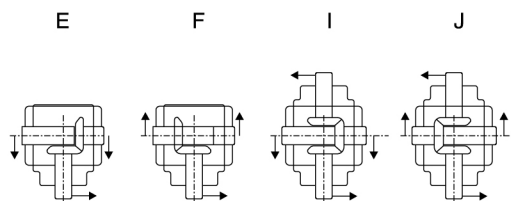
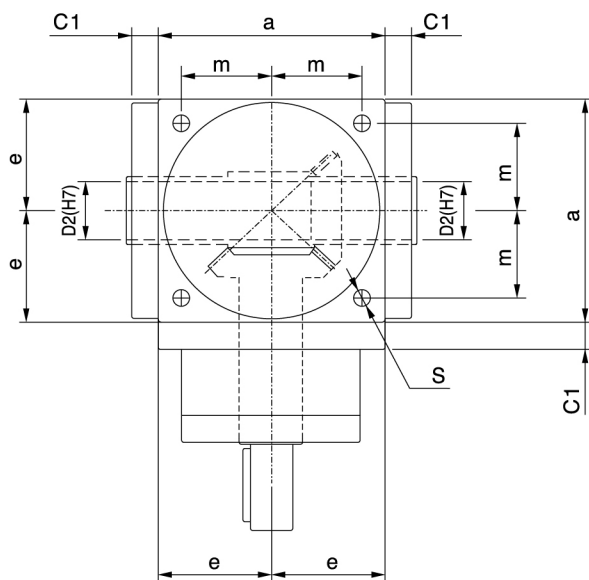
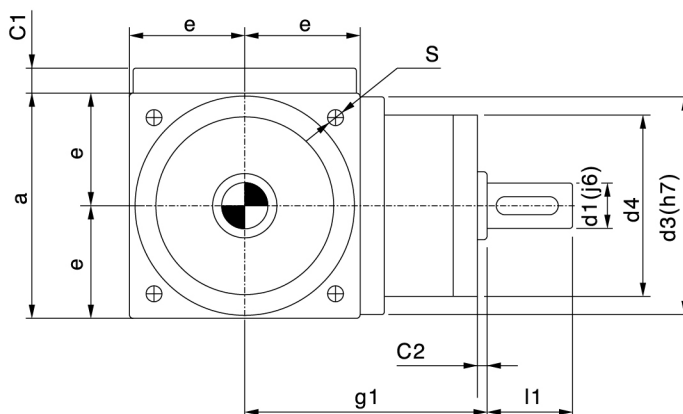
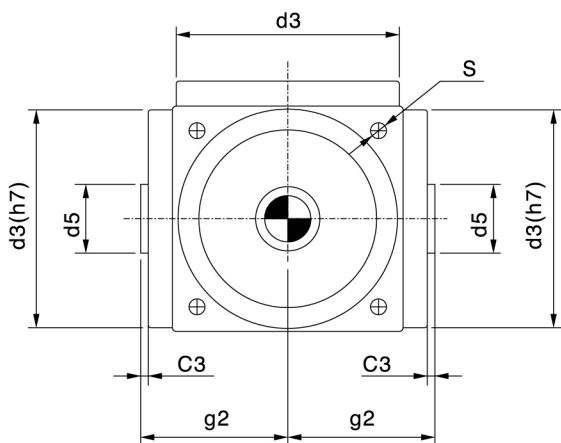

装配形式及旋转方向  
Mounting form and rotation direction

HD

型号 TYPE	a	C1	C2	C3	D2	l2	d3	e	g1	g2	m	S	i=1~2		i=3		i=4		i=5		i=1~3 d4	i=4~5 d4	重量 Weight Kg	加油 oil L
													d1	l1	d1	l1	d1	l1	d1	l1				
09	90	12	2	2	16	25	88	45	97	59	36	M6	18	35	16	30	11	23	11	23	72	62	6	0.2
11	110	12	2	2	22	35	108	55	116	69	44	M8	22	40	20	35	16	30	14	25	81	72	10	0.3
14	140	12	2	2	28	45	135	70	157	84	55	M10	32	50	26	45	20	35	16	30	98	81	20	0.4
17	170	15	2	3	38	55	165	85	181	103	67	M12	40	60	32	50	26	45	22	40	118	98	32	1
21	210	18	2	2	45	65	205	105	215	125	85	M16	45	70	38	55	32	50	30	50	128	110	60	2
24	240	18	2	2	55	75	235	120	225	140	95	M16	55	85	45	70	38	55	35	55	138	120	75	2.5
28	280	18	2	2	60	85	275	140	255	160	110	M16	60	110	50	80	45	70	42	70	150	135	115	3

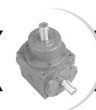

HDF09-HDF28带输入法兰，输出轴装式联接  
HD外形安装尺寸

HDF09-HDF28coupled of input shaft with input flange  
HD outline and mounting dimension

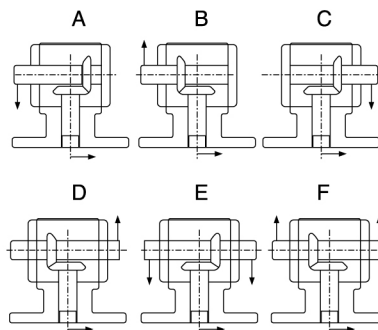
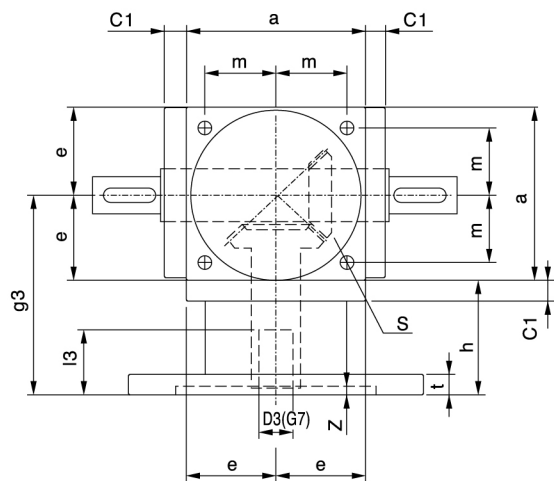
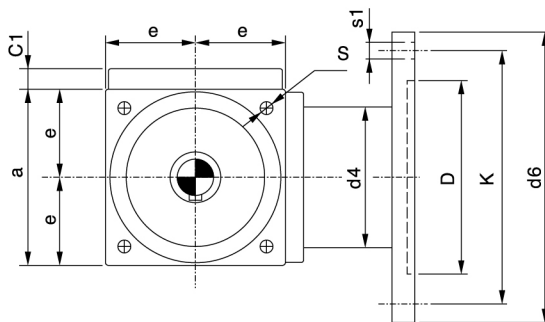
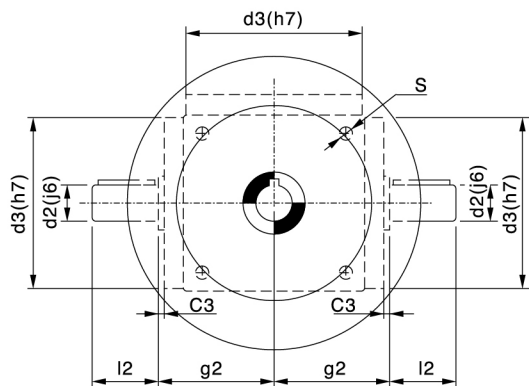

装配形式及旋转方向  
Mounting form and rotation direction

HD

型号 TYPE	a	C1	C2	d3	d4	d2	l2	i=1~2				i=3~5			
								D3X13				D3X13			
09	90	12	2	88	86	18	35	19X43	14X33	11X26	9X23	19X43	14X33	11X26	9X23
11	110	12	2	108	82	22	40	24X53	19X43	14X33	11X26	24X53	19X43	14X33	11X26
14	140	12	2	135	104	32	50	38X83	28X63	24X53	19X43	28X63	24X53	19X43	14X43
17	170	15	3	165	128	40	60	42X115	38X83	28X63	24X53	38X83	28X63	24X53	19X43
21	210	18	2	205	160	45	70	48X115	42X115	38X83	28X63	42X115	38X83	28X63	24X53
24	240	18	2	235	170	55	85	55X115	48X115	42X115	38X83	48X115	42X115	38X83	28X63
28	280	18	2	275	190	60	110	60X145	55X115	48X115	42X115	55X115	48X115	42X115	38X83

型号 TYPE	e	g2	g3	h	m	s	i=1~2				i=3~5			
							d6							
09	45	59	110	65	36	M6	200	160	140	120	200	160	140	120
11	55	69	130	75	44	M8	200	160	140	120	200	160	140	120
14	70	84	170	100	55	M10	300	250	200	160	300	250	200	160
17	85	103	215	130	67	M12	350	300	250	200	350	300	250	200
21	105	125	245	140	85	M16	350	300	250	—	350	300	250	200
24	120	140	265	145	95	M16	400	350	300	250	400	350	300	250
28	140	160	315	175	110	M16	450	400	350	300	400	350	300	

d6	D	K	S1	t	Z
120	80	100	4XM6	11	3.5
140	95	115	4XM8	11	3.5
160	110	130	4XM10	11	4
200	130	165	4XM10	14	4
250	180	215	4XM12	16	4.5
300	230	265	4XM12	16	4.5
350	250	300	4XM16	20	6
400	300	350	4XM16	20	6
450	350	400	4XM16	25	6





HDAF09-HDAF28带输入法兰, 输出轴装式联接  
H D 外形 安装 尺寸

HDAF09-HDAF28coupled of input shaft with input flange  
HD outline and mounting dimension

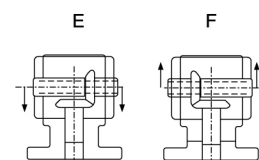
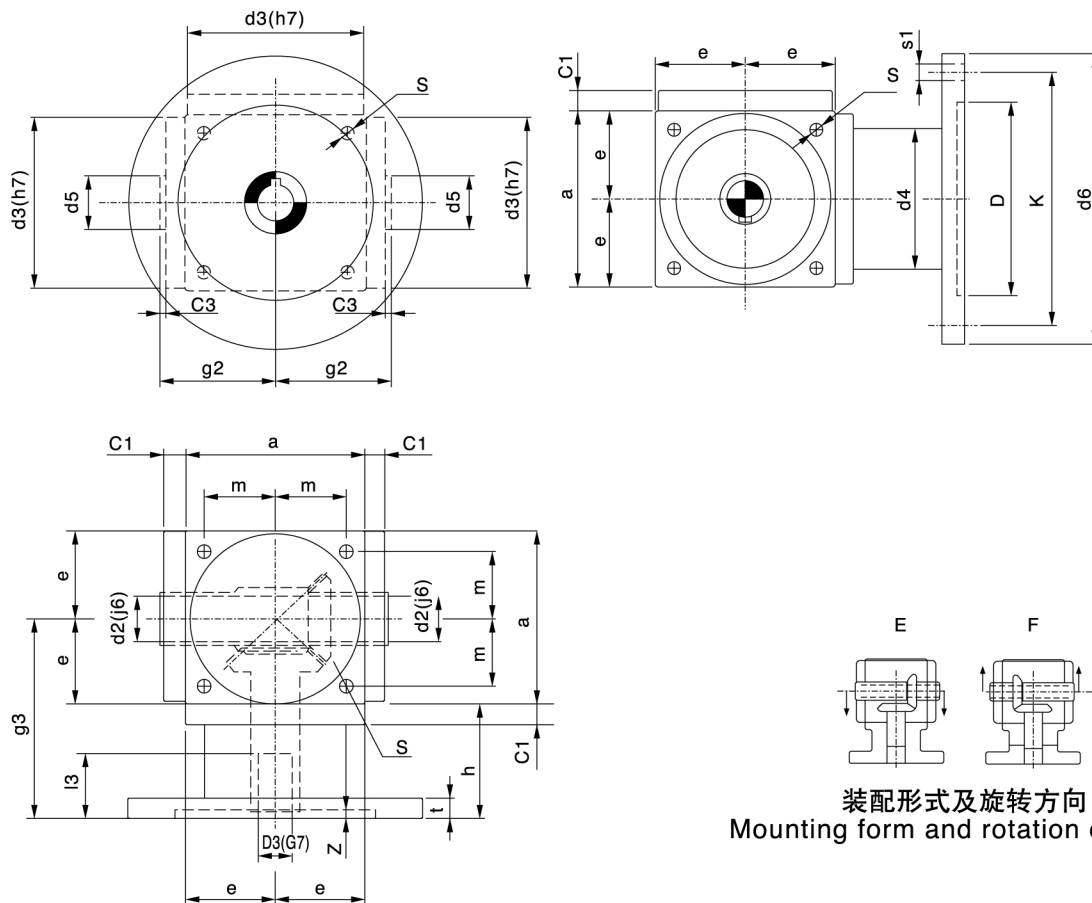

装配形式及旋转方向  
Mounting form and rotation direction

HD

型号 TYPE	a	C1	C2	d3	d4	d2	l2	i=1~2				i=3~5			
								D3X13				D3X13			
09	90	12	2	88	86	18	25	19X43	14X33	11X26	9X23	19X43	14X33	11X26	9X23
11	110	12	2	108	82	22	35	24X43	19X43	14X33	11X26	24X53	19X43	14X33	11X26
14	140	12	2	135	104	28	45	38X83	28X63	24X53	19X43	28X63	24X53	19X43	14X43
17	170	15	3	165	128	38	55	42X115	38X83	28X63	24X53	38X83	28X63	24X53	19X43
21	210	18	2	205	160	45	65	48X115	42X115	38X83	28X63	42X115	38X83	28X63	24X53
24	240	18	2	235	170	55	75	55X115	48X115	42X115	38X83	48X115	42X115	38X83	28X63
28	280	18	2	275	190	60	85	60X145	55X115	48X115	42X115	55X115	48X115	42X115	38X83

型号 TYPE	e	g2	g3	h	m	s	i=1~2				i=3~5			
							d6							
09	45	59	110	65	36	M6	200	160	140	120	200	160	140	120
11	55	69	130	75	44	M8	200	160	140	120	200	160	140	120
14	70	84	170	100	55	M10	300	250	200	160	300	250	200	160
17	85	103	215	130	67	M12	350	300	250	200	350	300	250	200
21	105	125	245	140	85	M16	350	300	250	—	350	300	250	200
24	120	140	265	145	95	M16	400	350	300	250	400	350	300	250
28	140	160	315	175	110	M16	450	400	350	300	400	350	300	

d6	D	K	S1	t	Z
120	80	100	4XM6	11	3.5
140	95	115	4XM8	11	3.5
160	110	130	4XM10	11	4
200	130	165	4XM10	14	4
250	180	215	4XM12	16	4.5
300	230	265	4XM12	16	4.5
350	250	300	4XM16	20	6
400	300	350	4XM16	20	6
450	350	400	4XM16	25	6